



OPERATING INSTRUCTION MANUAL

Mark 3XE Silver Recovery Unit



Hallmark Refining Corporation
1016 Dale Lane
PO Box 1446
Mount Vernon, WA 98274
Phone 360/428-5880
Toll Free 800/255-1895
Fax 360/424-8118
www.hallmarkrefining.com
Revised May 2007

Statement of Warranty and Liability

All equipment manufactured by Hallmark Refining Corporation is guaranteed against defects in materials and workmanship for a period of six months from the date of shipment from our factory. Any claimed defects must be reported, and the materials and/or equipment must be returned freight prepaid, to our plant within the guarantee period. Our liability for defects in material and/or workmanship shall be limited to the replacing or repairing, at our option, such defective materials and/or equipment at no cost to the purchaser. Warranty replacement items will be shipped regular surface freight at Hallmark Refining Corporation's expense. Any damages or loss occurring during shipment are not covered by this warranty but are the responsibility of the carrier(s). Please report all shipping damage to the carrier(s) immediately.

All materials and/or equipment furnished by other suppliers carry no warranty except said supplier's warranty as to materials and workmanship. Transportation, handling damage, wear and tear, and other causes of damage outside the control of the manufacturer are not covered by this warranty. Under no circumstances will Hallmark Refining Corporation be responsible for any damage, loss or liability of any nature arising out of the installation and/or use of the materials and or use of equipment furnished.

There are no other warranties, expressed or implied, except as stated above. The warranty becomes null and void if any devices or accessories other than those distributed or officially recommended by Hallmark Refining Corporation, are installed, or attached to this equipment.

Table of Contents

Statement of Warranty and Liability	1
An Introduction to Silver Recovery	3
Installation of the Mark 3XE Silver Recovery Unit	4
Operation of the Mark 3XE Silver Recovery Unit.....	7
Interpreting the Display.....	8
Silver Testing.....	9
Silver Testing Procedure.....	9
Silver Recovery Log	12
Washing and Shipping a Chemical Recovery Column	13
Changing a Column is as easy as 1 – 2 – 3 !	15
Troubleshooting the Mark 3XE Silver Recovery Unit.....	16
Poppet Valve Schematic.....	18
Parts List for the Mark 3XE Silver Recovery Unit	19
Maintenance Procedures for the Mark 3XE Silver Recovery Unit.....	20
Cleaning the Filter in the Mark 3XE Holding Tank	20
Priming the GRI Pump	21
Calibration of the GRI Pump	23
Instructions for Cleaning the Dishwasher Fitting on the Drain Line.....	24
Instructions for Using Iron Out in Photo Lab Applications	26
Instructions for Resetting the Hour Meter	27
Instructions for Changing the Battery.....	28
Suggested Maintenance Checklist	29
Mark 3XE Silver Recovery Unit Available Options.....	30
External Float Switch Alarm for Drain Monitor	30
External Float Switch Alarm for Liquid Overflow	30
Water iNjector for Flushing the Drain	30
Installation of the Mark 3XE Water iNjector	33
Specifications for the Mark 3XE Silver Recovery Unit	36

Illustrations

Illustration 1: Configuration of the Mark 3XE Silver Recovery Unit.....	6
Illustration 2: Changing a Column on the Mark 3XE System	14
Illustration 3: Orientation of the GRI Pump Poppet Valves and O-Rings	18
Illustration 4: Operational Schematic of the Mark 3XE System	22
Illustration 5: Operational Picture of the Silver Recovery Drain	25
Illustration 6: Configuration of the Mark 3XE iNjector System	31
Illustration 7: Flow Chart for Setting iNjector Delay and Flush Time.....	35

An Introduction to Silver Recovery

Silver recovery has become an increasingly important concern for photo labs as the local discharge limits for silver have become stricter. Properly maintained silver recovery systems can achieve most of these strict requirements and may even be a source of income. Proper operation and maintenance are vital to achieving both environmental and economic goals.

The images created on photographic films and papers are captured by exposure to silver halide. When these films and papers pass through their respective chemical processes, most of the silver is dissolved into one or more chemical solutions. These solutions are called Fixer for film and Bleach-Fix for paper, and in some processes a Stabilizer Rinse may be used that will contain silver. As the Fixer or Bleach-Fix removes silver, active ingredients are used up. Automated processing machines replenish these chemicals automatically. Excess chemistry, containing silver, overflows into waste holding tanks, which should be transferred to the Silver Recovery Unit or they may overflow directly into the Silver Recovery Unit.

As films and papers travel through these solutions, they carry chemicals from one step to the next. This means that any chemical step downstream from the Fixer or Bleach-Fix may also contain silver in its overflow. These will need to be treated if they contain silver above the local limit.

With today's heightened environmental concerns, most sewage agencies regard silver as a hazardous material. Silver bearing chemicals must be treated to remove the silver before the chemicals may be disposed. There are several ways to treat waste chemicals. The Mark 3XE Silver Recovery System is designed to de-silver silver bearing waste solutions on site. The level of silver that can remain in the disposed chemicals varies from location to location, but generally must fall below 5 parts per million (5 ppm). Many agencies however, require an even lower level of silver in a waste destined for sewer disposal.

The Mark 3XE Silver Recovery System will reduce the level of silver consistently to below 5 ppm when maintained and operated properly.

Hallmark Refining recommends that all photofinishing labs comply with the laws governing the disposal of hazardous materials for their operation.

Installation of the Mark 3XE Silver Recovery Unit

- Pump Station
- Containment Cart
- Plumbing Kit containing:
 - (1) Pre-assembled ¾" Exit Hose Assembly with Sample Valve and Grey Quick Disconnect Elbow
 - (1) Pre-assembled Quick Disconnect Bridge Assembly with Sample Valve and Quick Disconnect Elbows
 - (1) #12 Clamp
 - (4) Swivel Casters with Screws
 - (1) Operations Manual
- Two Mark 3X Quick Disconnect Silver Recovery Columns with Shipping Information

Tools Required:

- Phillips Screwdriver
1. Remove the pump station from its box. Open the small box containing the plumbing kit and locate the casters and screws. Install the casters on the bottom of the containment tray. Install all five swivel casters – all five casters are needed for stability. Place the pump station inside the tray, on the left.
 2. Remove the columns from their boxes and the quick disconnect cap covers from the top of the columns. Leave the caps tethered to the quick disconnect inserts. These caps will be needed to return the column to Hallmark Refining when it is exhausted. Some air may escape when the caps are removed. This is normal, as the columns are pressure checked at Hallmark Refining before shipping. Place the columns inside the containment tray, on the right.
 3. Connect the pump station to the “in” of the first column using the pre-assembled section of tubing provided. The red elbow should snap onto the red quick disconnect nipple fitting on the column.
 4. Connect the two columns together using the pre-assembled bridge assembly. The GREY “out” of the first column should lead into the RED “in” of the second column. The elbows are color-coded and should correspond to the color of the nipple fittings. RED is IN and GREY is OUT.

5. Attach the pre-assembled GREY quick disconnect elbow with a 10 foot length of 3/4" tubing from the outlet of the secondary column to the drain. This tubing needs to be long enough to reach the drain with a loop in it between the drain and the second column. (See Illustration 1) The loop creates a P-Trap effect and reduces rust formation.
6. From inside the tank, remove the section of tubing used to immobilize the float switches during shipping.
If the system is plugged in, the alarm will beep continuously until the top float switch cover is removed! When the system is turned on, the system will run continuously until the bottom float switch cover is removed!
If the alarm is activated by the top float switch cover, the digital readout will read t1f and will alternate with an error message until the top float switch cover is removed. If the unit was turned on, the unit will continue to run for one minute before turning off; however, the error message will disappear and 000 will take its place.
7. Remove the Phillips head screws on either side of the "helmet" covering the control box with digital display. The overflow battery alarm is shipped upside down in the holder to prevent the alarm from sounding during shipment. Flip the battery over and install it.
8. Check to be sure that all hose fittings and elbows have been securely attached. Plug the system into an uninterrupted source of power, preferably with a GFI Outlet.
9. Fill the pump station with water to test the system for leaks. **Both columns must be filled with water prior to the introduction of silver bearing waste.** A complete holding tank of water will have to be pumped through the unit before water will begin to exit the columns to the drain.
10. The system is now ready to process silver bearing waste. If the system is to be direct plumbed from the processor, remove one of the plugs from the rear of the system tank and install a polyethylene elbow. The most common connection would be to 5/8" tubing and would utilize a large barbed elbow and a large stainless steel hose clamp.



The Hallmark Mark 3XE Silver Recovery Unit should be located near an outlet and be easily accessible. The use of extension cords is not recommended.



Illustration 1: Configuration of the Mark 3XE Silver Recovery Unit

Operation of the Mark 3XE Silver Recovery Unit

The Mark 3XE Unit was developed to be a user-friendly system with little or no operator interaction. The system is designed to operate optimally with the Mark 3X Hallmark Silver Recovery Columns. The pump station has been designed to pump for 400 hours at a flow rate of 66 mL/min before the Mark 3XE Silver Recovery Unit will signal that a column needs to be changed.

The unit is programmed to operate for 375 hours before entering the next mode. When the pump is engaged, the system alternates between a digital reading of **run** and the number of hours the unit has pumped.

Top Red LED

The top red LED will light if the unit is over filled. An alarm will sound to inform the user that the holding tank contains too much liquid. The digital timer will also read **t1F**. The system will continue to operate and the alarm can be silenced. Refer to the troubleshooting guide for more information.

Yellow LED

The yellow LED will light after 375 hours of operation. In addition to the yellow light, an alarm will sound each time the pump starts. At this time, the primary silver recovery column needs to be changed. This cautionary mode will remain in effect for 25 hours or until the system has been reset.

Bottom Red LED

If the system has not been reset after twenty-five hours of operation in the yellow light mode, it will be disabled. The pump will not function until the unit is reset. The system should only be reset when a column change has been completed. If the CRC is not changed when instructed, the system can discharge silver to the drain and may eventually damage the pump.

Pressure Relief Valve (PRV)

Located between the Mark 3XE Silver Recovery pump and the primary silver recovery column, the Pressure Relief Valve (PRV) protects the pump and columns from damage from excessive pressure. Blockages in the tubing or dishwasher fitting obstruct the flow of liquid through the system. If a blockage occurs, the PRV diverts the flow of solution back into the holding tank.

Interpreting the Display

The three character digital display on the front of the electrical control panel monitors the Mark 3XE Silver Recovery Unit.

- run** Indicates the pump is running normally and all conditions are satisfactory.
- cnG** Indicates that it is time to change a column. The system has reached 400 pumping hours and will shut down until the unit is reset.
- 123** A three digit number indicating the number of hours the GRI bellows metering pump has run since it was last reset.
- t1F** Indicates the main holding tank is too full. The top float switch was activated. When this condition is present, the pump will continue to operate, but an alarm will sound.
- tEP** Indicates that the pump is in the test mode for pump calibration. This mode will stop the pump for 15 seconds, run the pump for 60 seconds and stop the pump again for another 15 seconds to allow an accurate pump output to be measured.
- Err** Indicates the top float switch started the pump. When this condition is present, the pump will continue to operate, but an alarm will sound. When the solution level has dropped, the bottom float switch must be investigated, as it is not working properly.
- dn1** Indicates that the external waste tank is full. The pump will stop and the alarm will sound. Turn off the Mark 3XE Unit and disconnect the plug from the waste tank. Dump the waste tank and reconnect the plug. Turn on the power to the Mark 3XE.
- dn2** Indicates that an optional float sensor has been activated. The pump will stop and an alarm will sound.

Under normal operating conditions, the digital display will alternately flash between **run** and the hour meter for pump.

When there is not sufficient effluent to activate the Mark 3XE Silver Recovery Unit to run, the digital display will show the hour meter for the metering pump ONLY.

When the top or bottom float switches are activated manually, the unit will operate for one minute after the float switch is released. This is to eliminate constant starting and stopping of the pump if the unit is direct plumbed.

Silver Testing

For optimum performance of the Mark 3XE Silver Recovery Unit, a silver dip test must be performed weekly. **For the most accurate reading, silver testing should be performed after the unit has been operating for at least two hours.** When **ANY** color change is detected between the columns, the first column is exhausted. Call Hallmark Refining Corporation at 800-255-1895 to order a new column.

Silver Testing Procedure

Materials:

- Silver test paper (Part Number 112-001)
This is supplied with your system. To reorder, contact Hallmark Refining Corporation. *This item is light sensitive and should be kept in the packaging in a dry drawer when not in use.*
- Standard personal protective equipment (Goggles, gloves and apron)
- Container to collect sample (Film canisters work well)

1. Put on your **Gloves, Apron and Goggles.**
2. **Turn off the silver recovery unit.**
3. Remove the plug on the second sample valve, closest to the drain. Place a graduated cylinder under the second sample valve and turn the lever to release any liquid and pressure in the line. **Opening the sample valve should only produce a dribble of liquid. If solution sprays out, this indicates the unit is pressurized. Refer to the troubleshooting guide for assistance.** Repeat this three times, pouring the chemistry back into the holding tank each time until the third sample. The first two will not give an accurate reading, so it is necessary to use the third collection. All solutions filling the graduate should be disposed of back in the Hallmark Mark 3XE Silver Recovery Unit Holding Tank.



4. Transfer some of the solution from the graduate sample taken at the drain line into a film canister. Secure the cap tightly on the canister and shake vigorously, but carefully for 3 minutes. Take off the lid and allow the canister to sit until the foam dissipates.
5. Repeat this procedure at the sample valve between the two columns.



6. Transfer some of this solution from the graduate sample taken between the columns into a film canister. Secure the cap tightly on the canister and shake vigorously, but carefully for 3 minutes. Take off the lid and allow the canister to sit until the foam dissipates.
7. Tear off about 2 inches of silver test paper. Each sample will require its own test strip. Put the test strip halfway in the solution for 5 seconds. Rinse the strip under slowly running water for 30 seconds. The silver will not rinse off. The color of the chemistry must be removed to get an accurate reading.



If the silver test strip is not yellow, it is time to change the primary column. **ANY** brown color is an indicator that it is time to change the primary silver recovery column. If the strip from the drain sample is darker than the sample between the columns, verify the columns were changed properly and are in the correct positions and retest. Rust is brown and can give a false positive reading. Following these procedures and allowing the rust to settle to the bottom of the container should give the most accurate results. Unless the columns were changed improperly, it is not possible for silver to be at the drain if silver is not coming out of the primary column. To order a new Hallmark Column, call Hallmark Refining Corporation at 800-255-1895.



Silver test paper indicates column is performing optimally.

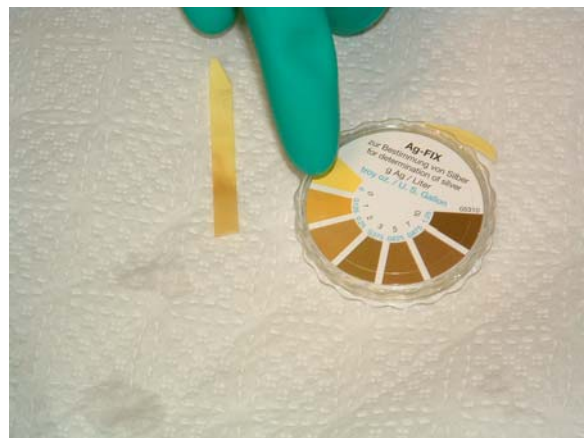

Silver test paper indicates primary column is exhausted.

Silver Recovery Log

Month:		Year:	
---------------	--	--------------	--

Silver Test Paper Results

	(Attach test strip here)	(Date and Initial)
WEEK 1		
WEEK 2		
WEEK 3		
WEEK 4		
WEEK 5		

Column Information

	Serial Number	Date Installed	Initials
Primary			
Secondary			
2nd Primary			
2nd Secondary			

- ◆ *Transfer column information from last month's log sheet. At month end, transfer current column information to next month's Silver Recovery Log.*

Washing and Shipping a Chemical Recovery Column

1. When it is time to change a column on the silver recovery unit, the column being removed will need to be rinsed with clean water before removal to comply with EPA (Environmental Protection Agency) and DOT (Department of Transportation) laws. Failure to rinse the column prior to removal could result in a fine for the improper shipment of “hazardous waste”.
2. Fill the holding tank of the Mark 3XE Silver Recovery Unit with cold tap water and allow it to be pumped through the system. The EPA requires that the column be triple rinsed prior to shipping. **It will take one holding tank of water to equal three times the volume of the Mark 3X Column.** Washing can stop when no color change is detected in silver estimating paper used to sample the effluent from the column. To be certain that no soluble silver is present, allow the cartridge to stand overnight and then test a sample of the solution. If silver is present, repeat the washing step until no visible silver is present when tested. The silver test paper should remain yellow.
3. After completing the rinse step, remove the primary column and slide the secondary column into the primary position (connected to the pump). Install a new column in the secondary position (closest to the drain) and reinstall the quick disconnect elbows and tubing. Be certain all connections are secure before turning on the Silver Recovery Unit. The RED Quick Disconnect fitting is the inlet and the GREY Quick Disconnect fitting is the outlet of the column.
4. The rinsed column can now be capped and packaged for shipment.
5. Fill the holding tank with water and allow the water to pump through the system before filling the tank with additional silver bearing waste. Alternatively, the new column being installed into the secondary position may be manually filled with 3 gallons (12 Liters) of water. The columns work most effectively when they are filled with water before processing silver.

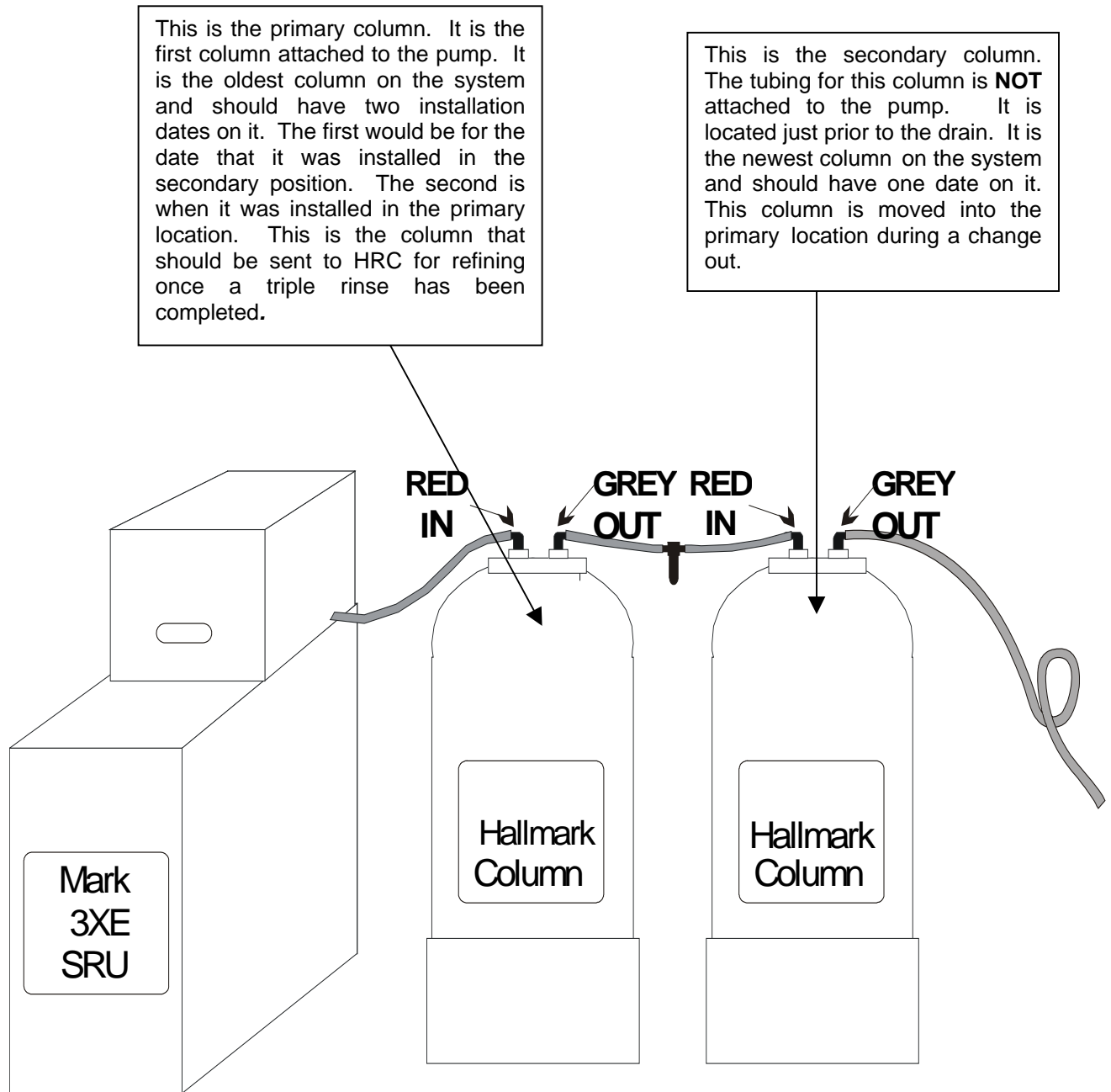
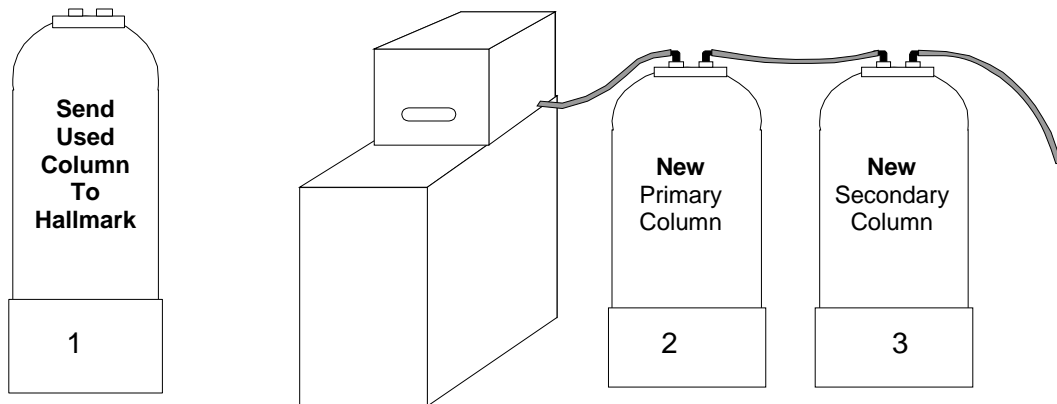
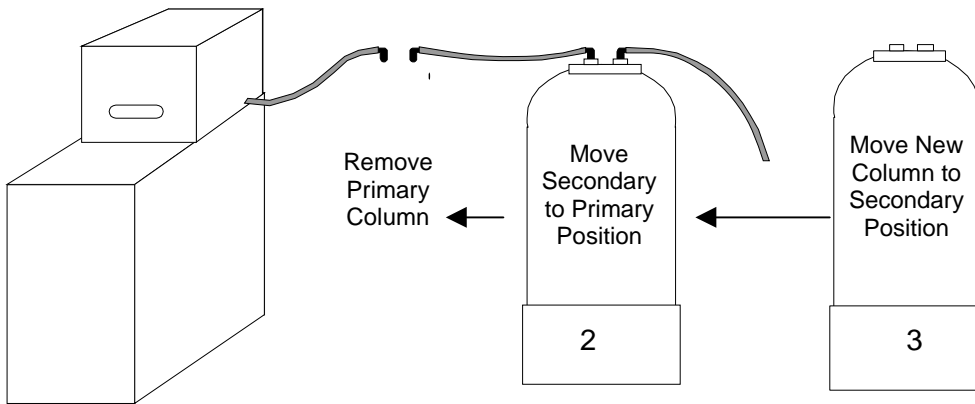
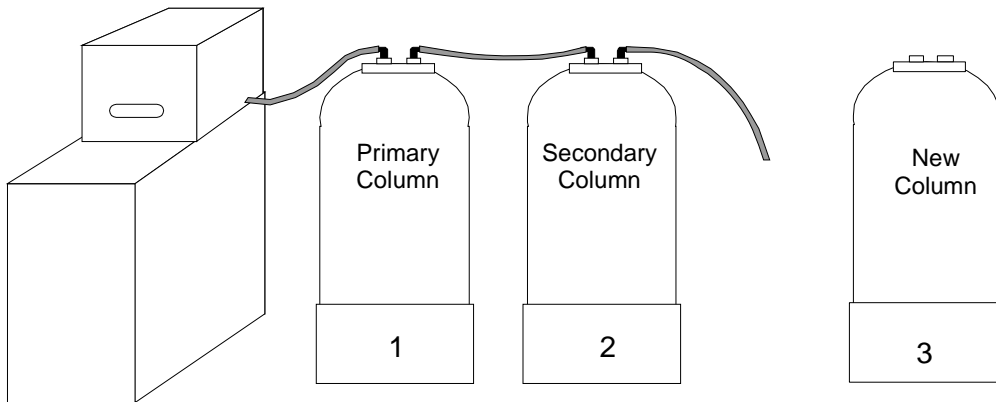

Illustration 2: Changing a Column on the Mark 3XE System

Changing a Column is as easy as 1 – 2 – 3 !



Troubleshooting the Mark 3XE Silver Recovery Unit

<p>The pump has no power.</p>	<ul style="list-style-type: none"> • Does the digital display have a visible reading? • Check the power source. Is it plugged in? If not, plug it in and/or turn the rocker switch to the on position. • Does the display read Cng? If so, follow instructions for resetting the hour meter. • Is the GFI circuit breaker for the electrical socket tripped? Check the reset button. Inspect for cause. • Check the float switches in the holding tank. Does the bottom one turn the pump on when it is lifted? Does the top float switch turn it on when it is lifted? If not, a new drop in assembly may be needed. • Was it whining or humming when it stopped? If so, the motor may be burned out. <p>Please call Hallmark Refining @ 1-800-255-1895 to order parts.</p>
<p>The pump is running, but the solution is moving very slow.</p>	<ul style="list-style-type: none"> • Is the PRV (Pressure Relief Valve) activated? • Is there pressure at the sample valves? Wearing PPE, begin checking at the LAST sample valve for pressure and work your way backward. If high pressure exists at the last sample valve, follow the instructions for cleaning the dishwasher fitting. • Has a pump output test been done? Disconnect the tube from the in valve of the first column. Place the tube in a graduated cylinder. When the first drop of liquid enters the cylinder, start timing the output for one minute. Turn off the unit after one minute. The output should be between 50-66 milliliters. • If the pump output is less than recommended, do the following: Check and clean the hose strainer in the holding tank. Inspect the poppet valves and follow the instructions for priming the pump.
<p>The pump is running, but the chemistry level in the holding tank is not dropping.</p>	<ul style="list-style-type: none"> • Is the PRV (Pressure Relief Valve) activated? • Is there pressure at the sample valves? Wearing PPE, begin checking at the LAST sample valve for pressure and work your way backward. If high pressure exists at the last sample valve, follow the instructions for cleaning the dishwasher fitting. • Has a pump output test been done? Disconnect the tube from the in valve of the first column. Place the tube in a graduated cylinder. When the first drop of liquid enters the cylinder, start timing the output for one minute. Turn off the unit after one minute. The output should be between 50-66 milliliters. • If the pump output is less than recommended, do the following: Check and clean the hose strainer in the holding tank. Inspect the poppet valves and follow the instructions for priming the pump.

<p>The pump is running, but the chemistry level in the holding tank is not dropping. (continued)</p>	<ul style="list-style-type: none"> • Is the bellows (plastic accordion part) warped or leaking? The bellows tends to warp when pumping against a blockage. ALWAYS relieve pressure at the sample valves before disconnecting the QD fittings. The PRV is intended to prevent this from happening. Make sure the blockage is removed before the new bellows is installed. Please call Hallmark Refining @ 1-800-255-1895 to order this part.
<p>The Mark 3XE System is leaking.</p>	<ul style="list-style-type: none"> • Is the PRV (Pressure Relief Valve) activated? • Is there pressure at the sample valves? Wearing PPE, begin checking at the LAST sample valve for pressure and work your way backwards. If high pressure exists at the last sample valve, follow the instructions for cleaning the dishwasher fitting. • Is there liquid on top of the column near the elbows? If so, check to be sure the QD fittings are clicked into place. ALWAYS relieve pressure at the sample valves before disconnecting the QD fittings. • Is there a hole in the bellows (plastic accordion)? See section above. • Are any clamps loose? • Are the sample valves closed with the lever parallel to the ground? • Is the O-ring on the QD nipple present? This can be greased with Vaseline to create a better seal if the O-ring is worn out. • Are the columns exhausted? • Is the drain plug at the bottom of the column cracked or leaking?
<p>The system won't stop beeping.</p>	<ul style="list-style-type: none"> • Was the holding tank over filled? Look inside of the holding tank and see if the liquid is above the top float switch. If it is, the tank is too full. The pump will continue to operate. The alarm can be temporarily disabled at the control box, but it must be turned back to normal as soon as the liquid level drops below the top float switch. • Was the unit shut off? Overfilling may occur if power to the unit is turned off. If the alarm switch is not in the normal position, there will be no warning alarm for the overfilled tank if there is no AC electrical power. • Did liquid continue to enter the tank after the Change Now hours have elapsed? This condition would show the orange LED turned on and the display showing t1F alternating with Cng. Reset the hour meter and call Hallmark Refining to confirm if it is time to change the column. • Does a dN1 or dN2 signal appear in the digital display? If so, check the external liquid sensors. • Did the liquid enter the tank faster than the pump could remove it?
<p>The system runs 24 hours and never turns off.</p>	<ul style="list-style-type: none"> • Were the float switch covers removed from the float switches when the unit was installed? • There may be something under the bottom float switch that won't allow the system to shut off. • Check the float switches for sediment build up. Gently unhinge and clean the bottom and top float switches. • Has the float switch toggle been hinged upside down?

Poppet Valve Schematic

Poppet valves open and close to allow liquid to flow in and stay in the hoses. For this reason, the point of the poppet valve **must** point into the flow of the liquid. The O-Ring associated with the poppet valve **must** be on the outside of the poppet valve to seal it properly – it will **ALWAYS** be installed last.

If the gaskets of the poppet valves are not properly seated or the cone is twisted and not able to open and close freely, slow pumping or even no liquid movement will be experienced. If this is a continuous problem, check the rest of the system for blockage.

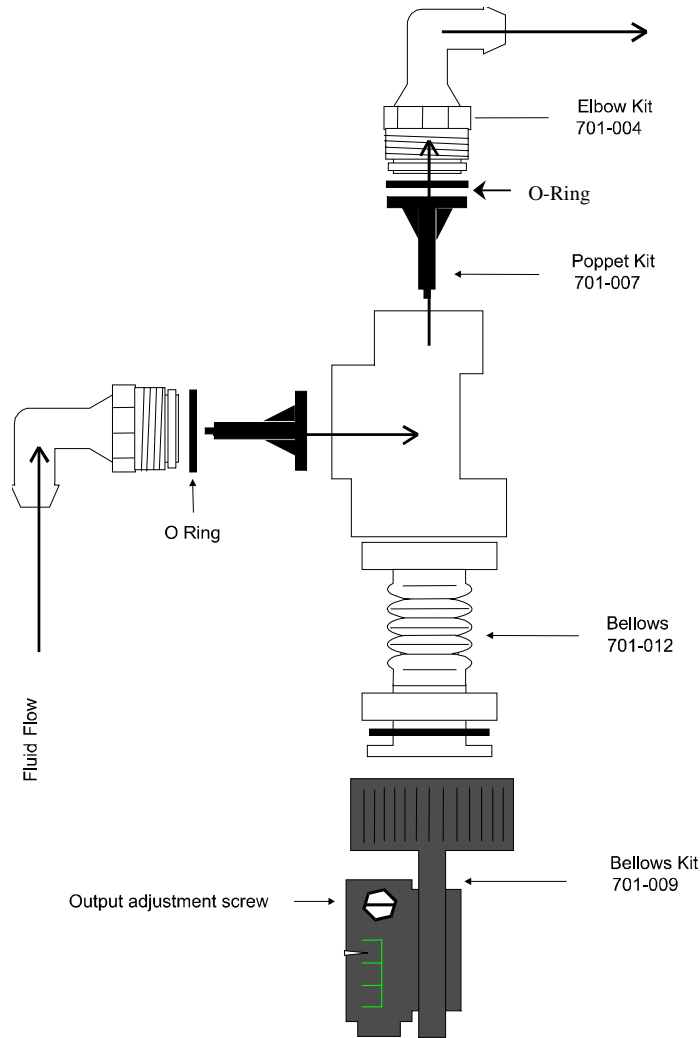

Illustration 3: Orientation of the GRI Pump Poppet Valves and O-Rings

Parts List for the Mark 3XE Silver Recovery Unit

Part Number	Part Description
915-060	Drop In Assembly with PRV and Red QD
602-122	Holding Tank
602-486	Containment Tray with Casters
241-002	Swivel Casters
915-006	3/4" Sample Valve Assembly
511-002	1/2" Threaded Plug for Sample Valve
510-065	5/8" Poly MPT Elbow
511-005	Threaded Plug for Hallmark Column
917-026	3/4" QD Bridge Assembly with Sample Valve
917-027	3/4" QD Exit Hose Assembly with Sample Valve
520-004	1/4" Hose Strainer Assembly
520-005	Replacement Hose Strainer
520-025	Complete Hose Strainer Assembly with 1/4" Tubing
106-007	3/4" Clear Tubing
106-003	3/8" Clear Tubing
106-002	1/4" Clear Tubing
522-042	3/4" Plastic Hose Clamp
522-036	3/8" Plastic Hose Clamp
917-048	Pressure Relief Valve Assembly
514-036	3/8" x 3/4" Hose Adapter
916-003	Parts Kit with QD Fittings
916-005	Parts Kit with QD Fittings and Poppet Valves
701-002	GRI Bellows Pump
701-007	GRI Poppets with O-Rings (set of two)
701-012	GRI 1" Bellows
701-009	GRI 1" Bellows Kit
701-004	GRI 3/8" Elbow Connectors (set of two)
112-001	Silver Estimating Paper
130-018	2.5 Gallon Container with Alarm for Dn1
524-688	Smart Alarm for Dn1
906-054	iNjector System
524-680	External Liquid Sensor for Dn2

Maintenance Procedures for the Mark 3XE Silver Recovery Unit

Cleaning the Filter in the Mark 3XE Holding Tank

For optimum performance of the Mark 3XE Silver Recovery Unit, the filter in the holding tank should be checked and cleaned periodically.

To clean the filter:

1. Put on your **Gloves**, **Apron** and **Goggles**.
2. **Turn off the silver recovery unit.**
3. Open the lid of the holding tank. Pull up the holding tank filter located at the end of the flexible tubing.



4. Unscrew the filter.



5. Rinse the filter under running water. Use a brush if necessary.
6. Reattach the filter to the fitting by screwing it back in place and submerge the filter into the liquid in the holding tank.
7. Turn on the Silver Recovery Unit and resume normal operation.

Priming the GRI Pump

1. Put on your **Gloves, Apron and Goggles.**
2. **Turn off the silver recovery unit.**
3. With a container handy to catch any liquid, slowly open the sample valve on the exit tubing to relieve any pressure. Repeat this procedure at the sample valve between the columns. If pressure exists, follow the instructions to clean the dishwasher fitting before proceeding.
3. Remove the clear elbow on the side of the pump so that the side poppet valve and O-Ring are accessible. The tubing does not need to be removed. The elbow is held on by a swivel connector. Twist the swivel connector counter clockwise. Remove the O-Ring and poppet valve.
4. Remove the clear elbow on the top of the pump so that the top poppet valve is accessible. The tubing does not need to be removed. The elbow is held on by a swivel connector. Twist the swivel connector counter clockwise. Remove the O-Ring and poppet valve. This is best achieved by pushing the poppet valve up from inside the pump.
5. Clean both poppet valves with warm soapy water. Inspect the poppets and O-Rings to ensure they are in good working order.
6. Grasp the point of the poppet valve with two fingers and place the flat end of the poppet valve into the side of the pump head so that the point of the poppet valve is facing out of the pump head. Place the O-Ring over the point of the poppet valve. Twist on the side elbow hand tight over the point of the poppet valve and O-Ring. **O-Rings ALWAYS go in last. The O-Ring creates a seal between the poppet valve and elbow.**
7. Using a squirt bottle of water, fill the reservoir (bellows) with water until it slightly spills over.
8. Install the top poppet into the pump point down. Place the O-Ring onto the flat part of the poppet valve. **O-Rings ALWAYS go in last. The O-Ring creates a seal between the poppet valve and elbow.** Twist the clear plastic top elbow on hand tight. Refer to Illustration 3 on Page 19 for a diagram of the orientation of the poppet valves.

9. Be certain there are enough chemicals in the holding tank to cover the bottom float switch.
10. Have a container ready to catch the liquid that will come out of the pump and tubing still detached from the column.
11. Turn the power on to the Silver Recovery Unit. As the bellows begins to move up and down, it will pull the liquid up into the pump and push the liquid out as the bellows compresses together. If air bubbles are present or the liquid appears to hesitate coming up, air is getting into the pump and the elbows should be tightened or the poppet valves need to be replaced.
12. After 20-30 seconds, liquid should begin to flow through the pump.

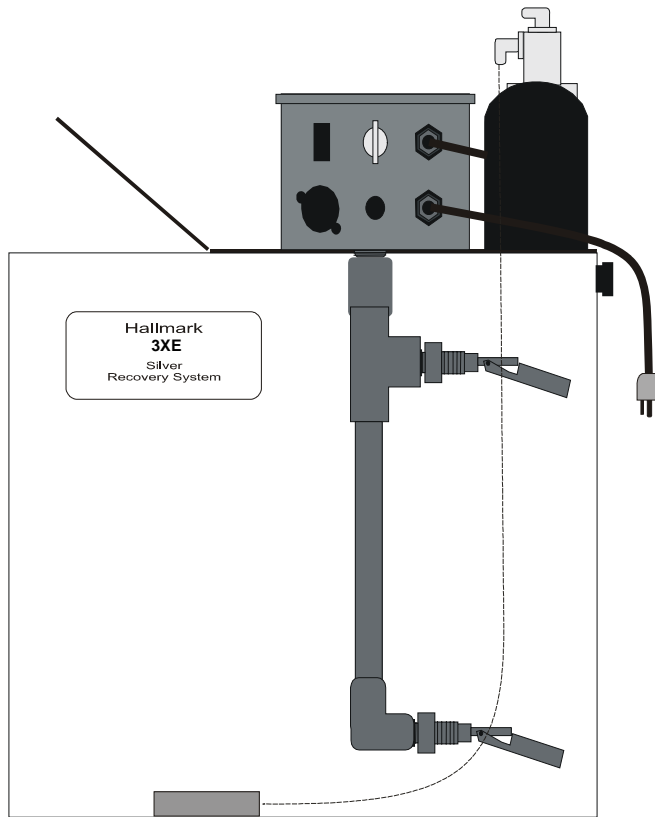

Illustration 4: Operational Schematic of the Mark 3XE System

Calibration of the GRI Pump

The flow rate of the bellows can be verified by the following procedure:



During the following steps, silver bearing waste may have to be handled, use proper personal protective gear, including approved safety goggles and gloves.

1. Put on your **G**loves, **A**pron and **G**oggles.
2. **Turn off the silver recovery unit.**
3. With a container handy to catch any liquid, slowly open the sample valve on the exit tubing to relieve any pressure. Repeat this procedure at the sample valve between the columns. If pressure exists, follow the instructions to clean the dishwasher fitting before proceeding.
4. Press the large grey CPC button on the red elbow connected to the primary column and remove the red QD IN elbow on the first column.
5. Place a 250 mL graduated cylinder under the disconnected tubing and red elbow. Turn on the power to the Silver Recovery Unit.
6. Press the **Pump Test** button on the front of the control box. The unit will stop running and alternate on the digital display **tEP** (test **E**ffluent **P**ump) and a countdown of seconds as it counts down for 15 seconds.
7. The pump will begin to operate automatically for 60 seconds.
8. Read the amount of liquid collected in the graduate.
9. Pour the collected liquid back into the Effluent Collection Tank.
10. Repeat this procedure at least three times to verify it is an accurate reading. Ideally, the pump should discharge 100 mL/min. Any reading within 20% of this is adequate.

If the liquid level in the holding tank is above the lower float switch, the pump will automatically begin pumping effluent again 15 seconds after the 60-second pump output test ends.

Instructions for Cleaning the Dishwasher Fitting on the Drain Line

For optimum performance of the Mark 3XE Silver Recovery Unit, the dishwasher fitting where the hose attaches from the last column to the sink should be checked and cleaned periodically.

To clean the dishwasher fitting:

1. Put on your **Gloves**, **Apron** and **Goggles**.
2. **Turn off the silver recovery unit.**
3. With a container handy to catch any liquid, slowly open the sample valve on the exit tubing to relieve any pressure.
4. Remove the exit tubing from the dishwasher fitting by loosening the hose clamp. Pull the tubing off the dishwasher fitting.
5. Insert a long screwdriver into the dishwasher fitting pipe and pull the debris out of the fitting. Try not to allow the debris to go down the pipes as it could cause a clog further down stream.
6. Once the debris has been removed to the best of your ability, squirt water into the dishwasher fitting. If the water drains, the fitting is clear. If the water does not drain, the clog is beyond the reach of the screwdriver and will require a plumber to snake the pipes.
7. Once the fitting is clear and water can drain freely, reattach the exit hose to the dishwasher fitting and tighten the hose clamp.
8. Turn on the Silver Recovery Unit and resume normal operation.
9. If pressure builds up again at the last sample valve, the clog has not been removed. Repeat this procedure or contact a plumber to clear the drain professionally.

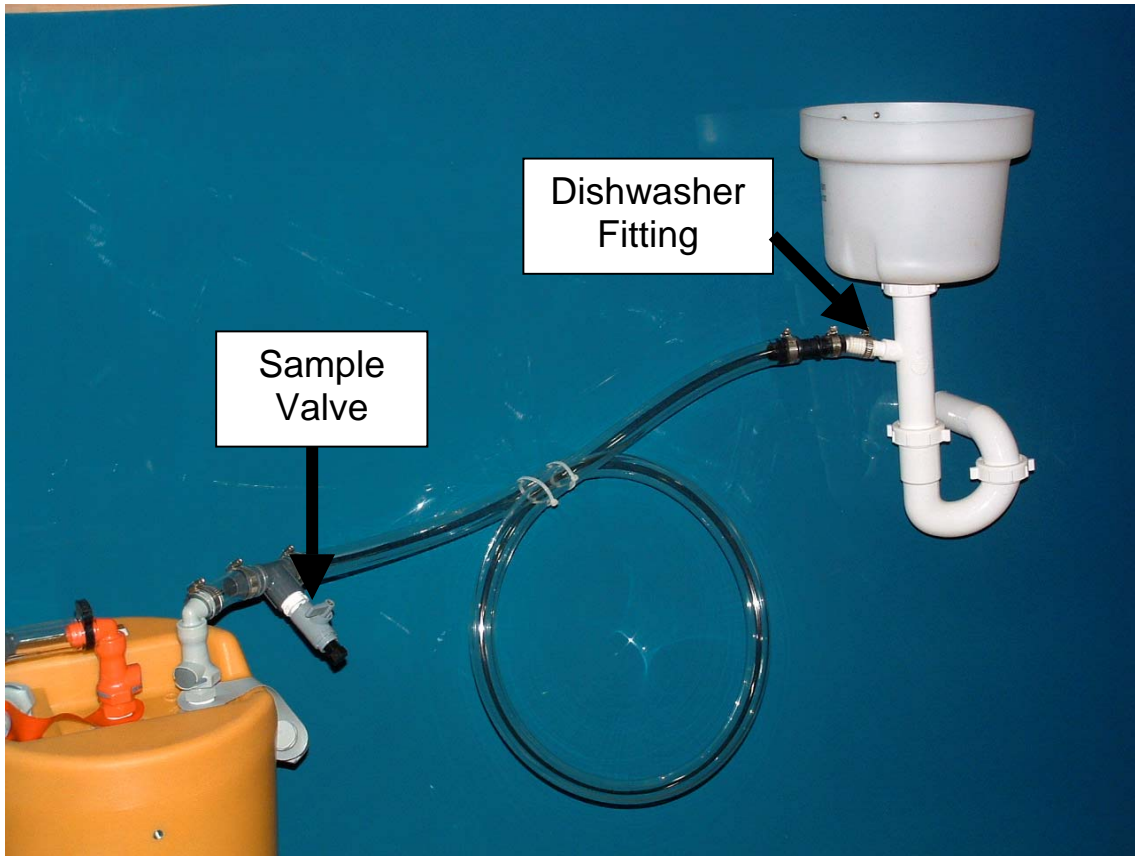
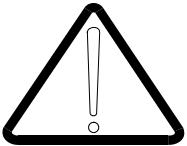

Illustration 5: Operational Picture of the Silver Recovery Drain



If the clog requires a plumber to fix it, this does not mean that all photo operations have to cease. The hose that would normally be attached to the dishwasher fitting can be put into a bucket. When the bucket is full, this container can be carried to another sink in the store and dumped down the drain.

Instructions for Using Iron Out in Photo Lab Applications

Iron Out should be used as a preventative measure to reduce iron build up in photo labs that use steel wool type silver recovery units. Photo labs that operate a liquid transfer station are at the most risk of damage from iron build up. Excessive iron buildup will cause liquid transfer station malfunction and clogged pipes. It is recommended that Iron Out be used weekly for best results.

Use Iron Out as follows:

1. Once a week, mix 1 cup Iron Out with 1 gallon warm water in a container. Be sure the Iron Out dissolves completely. Pour it down the drain, preferably after the lab has closed. This allows the Iron Out sufficient time to sit in the liquid transfer station's holding tank or pipes and dissolve iron buildup.

DO NOT pour the powdered Iron Out down the drain first, and then flush the sink with water. Undissolved Iron Out tends to crystallize and contributes to the buildup problem.

2. Iron Out will not solve current drainage problems. It is intended as a preventative measure only. Current problems need to be addressed and resolved before Iron Out can be effective.



Instructions for Resetting the Hour Meter

Many of the Mark 3XE Silver Recovery Units have been preset to operate for 375 hours before a yellow light on the control box will light with a corresponding **CHANGE CRC SOON** message. The unit will continue to operate for 25 hours with the yellow light. At 400 hours, a red light will illuminate with a corresponding **CHANGE CRC NOW** message. The red light will remain illuminated and the Silver Recovery Unit will be shut off permanently until the unit is reset. This does not necessarily mean it is time for a column change. It **does** mean the Silver Recovery Unit needs to be reset to resume normal operations. The hour meter is a guideline for the volume of waste a column can accept before it is exhausted. Chemical composition, silver concentrations and pH affect silver recovery. Because of these variables, silver test paper used between the columns is the most effective tool to make an accurate determination if the column is exhausted. Refer to the guidelines in this manual for more information on using silver test paper.

To reset the hour meter:

1. While the Silver Recovery Unit is on, gently press and hold the Pump Test/Reset Hour Meter Button until two beeps are heard (about 15 seconds). Let go of the button after the two beeps.
2. The hour meter will return to 000.



The Mark 3XE Silver Recovery Unit should resume normal operation. When there is enough liquid to cover the bottom float switch, the display should fluctuate between **run** and **000**.

Instructions for Changing the Battery

The battery should be checked every time a column is changed. The 9-Volt battery is located on the outside of the control box. The battery can be checked by the following procedure:

1. Turn off the power to the unit.
2. Place the alarm switch in the cancel position.

If the alarm sounds loudly, the battery is fine. If the alarm sounds weak or not at all, the battery needs to be replaced.

To Change the Battery:

1. Turn off the power to the unit.
2. Disconnect the power cord from the wall.
3. Remove the blue hood covering the control box and pump.
4. Remove the battery by prying the battery loose from its holder. Be careful not to dislodge any wires from their terminal connectors.
5. Replace the battery with a fresh 9-Volt battery and replace the hood covering the control box and pump.
6. Plug in the Mark 3XE Silver Recover Unit and turn it on.

Suggested Maintenance Checklist

As with any piece of equipment, the Mark 3XE Silver Recovery Unit has maintenance requirements. The following suggestions are intended to keep the Silver Recovery Unit working optimally and efficiently with minimal down time.

Weekly Checklist:

- Flush holding tank with five Liters of warm water.
- Clean holding tank filter as required using instructions provided.
- Perform and log silver testing to determine if column should be changed. If at any time high pressure is present at the sample valves, follow the instructions provided for cleaning the dishwasher fitting.
- Flush drain with Iron Out using instructions provided.

Biannual Checklist:

- Clean poppet valves and replace if necessary.
- Clean and/or change soiled/clogged tubing.
- Clean and/or replace dishwasher fitting.
- Order spare parts as necessary to prevent expensive emergency overnight shipments.

Mark 3XE Silver Recovery Unit Available Options

There are several options available on the Mark 3XE Silver Recovery Unit. The control box has been equipped with several options for a variety of situations to enable the user to optimize the Mark 3XE Silver Recovery Unit. The unit is fully operable without the use of any of these options, but the following are available.

External Float Switch Alarm for Drain Monitor

A port located on the side of the control box is available to attach an external float switch. If the user does not have a drain for the waste exiting the silver recovery unit, a 2.5-gallon container with a drain monitor is available. The float switch and alarm for this container would connect to the control box so that the unit would be automatically turned off when the container is full. The waste drum could then be disconnected, emptied and reconnected to the Silver Recovery Unit.

When using this option on the Mark 3XE, the system **must be turned off** prior to disconnecting the drain jack. **DO NOT unplug the drain jack without turning off the unit.** The system will continue to operate if the power is not turned off.

External Float Switch Alarm for Liquid Overflow

A port located on the side of the control box is available to attach a liquid overflow alarm. The sensor can be placed near a drain or in the containment tray of the Mark 3XE Silver Recovery Unit. If the alarm is triggered, the Mark 3XE will alarm and shut down operations until the alarm is cancelled and/or the sensor is disconnected.

When using this option on the Mark 3XE, the system **must be turned off** prior to disconnecting the overflow alarm jack. **DO NOT unplug the overflow alarm jack without turning off the unit.** The system will continue to operate if the power is not turned off.

Water iNjector for Flushing the Drain

Two jacks are located on the side of the control box to attach a solenoid valve that will inject liquid at timed intervals into the drain. The solenoid must be attached to a tee connector on the cold water connection of the water supply. The amount of time the water is injected as well as the amount of water can be adjusted. Refer to Illustration 6 for further instructions.

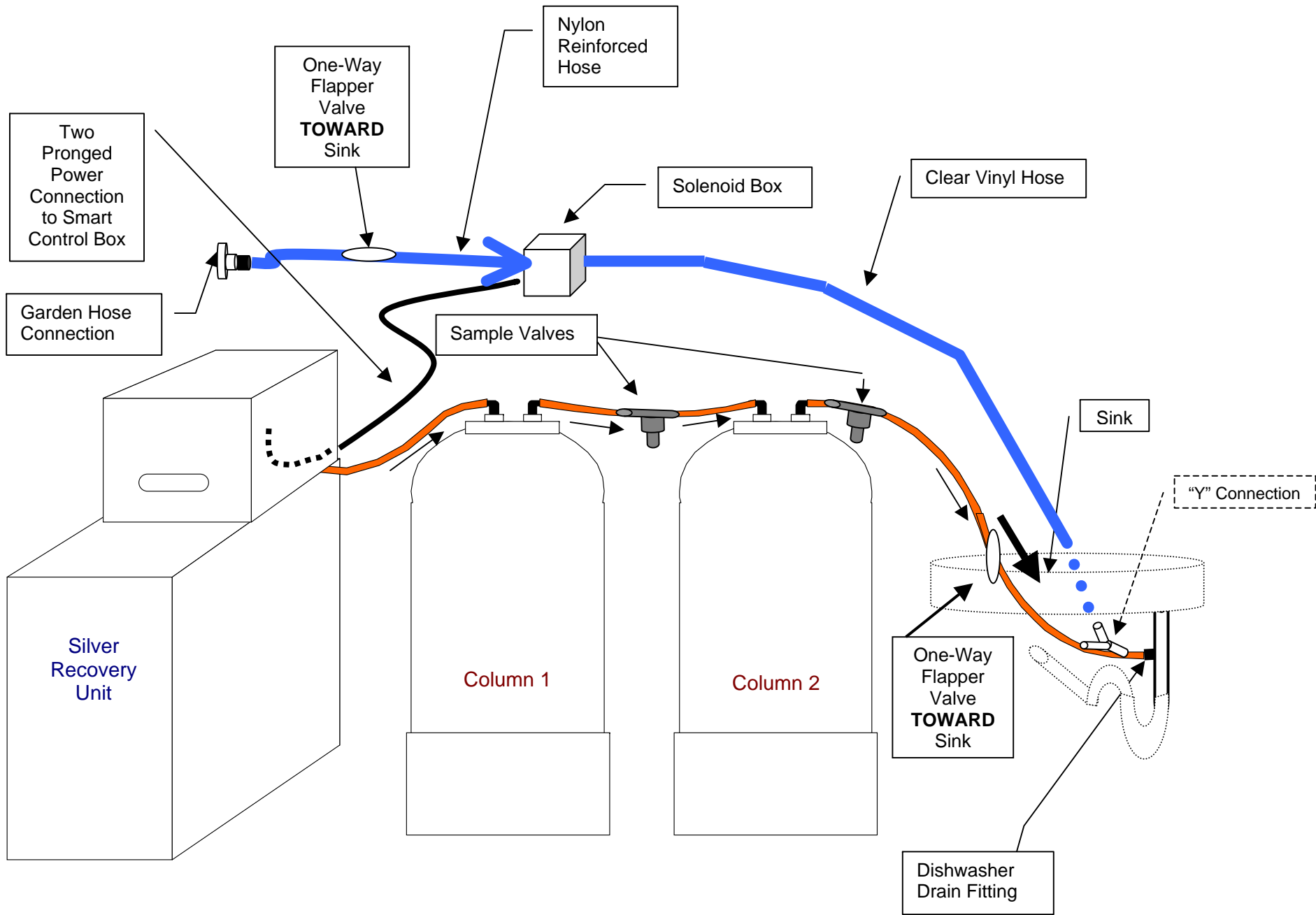

Illustration 6: Configuration of the Mark 3XE iNjector System

Installation of the Mark 3XE Water iNjector

Before installing the iNjector, the site should be prepared in advance with the following:

- Standard 110 VAC Electrical outlet
- Dishwasher drain fitting or fitting on Liquid Transfer Station
- Garden Hose Bib
- Operational Mark 3XE Silver Recovery Unit manufactured by Hallmark Refining Corporation with Two One-Way Flapper Valves

Installation Instructions:

1. Open the box containing the solenoid and tubing. Remove all components. The box should contain:
 - Gray box containing solenoid with 2 hoses and a low voltage lead attached as follows:
 - ◇ 6' braided tubing with garden hose fitting, attached to the IN side of the solenoid box.
 - ◇ 6' - 1/2" clear vinyl tubing attached to the OUT side of the solenoid box.
 - ◇ Low voltage electrical connection with 2 male plugs, attached to solenoid box.
 - ◇ "Y" connector attached to clear tubing and 2 hose clamps.
 - ◇ One-way flapper valve for exit line of the Silver Recovery Unit.
 - ◇ 4 self-tapping screws.
2. Locate the gray solenoid box in a place convenient to the hose bib and the drain or Liquid Transfer Station. Attach the box to the wall or sink cabinet with the screws provided.
3. Connect the garden hose fitting on the braided hose to the hose bib. Tighten completely. The fitting has a screen/washer that must be in place before attaching it.
4. Attach the "Y" in the line so that the bottom leg of the "Y" is attached to the line going directly to the drain. **This should be positioned as close to the drain as possible.** The solenoid and the line from the column attach to the upper legs of the "Y". Secure with hose clamps provided.
5. Plug the 2 male plugs into the control box of the Silver Recovery Unit. The ports are marked "iNjector Connection". ***Either plug can go in either port.***

6. Between the last sample valve and the “Y” connection fitting for the iNjector, install the one-way flapper valve in the line, clamping it firmly onto the tubing on either side. **The FLOW must be pointed towards the sink.** This valve prevents liquid from backflowing into the silver recovery columns.
7. Open the valve on the garden hose bib. Check for leaks and tighten connections if necessary.
8. Turn the Mark 3XE Silver Recovery Unit on. The iNjector solenoid will be activated when the pump on the Silver Recovery Unit starts.

FLOW CHART FOR SETTING INJECTOR DELAY AND FLUSH TIME

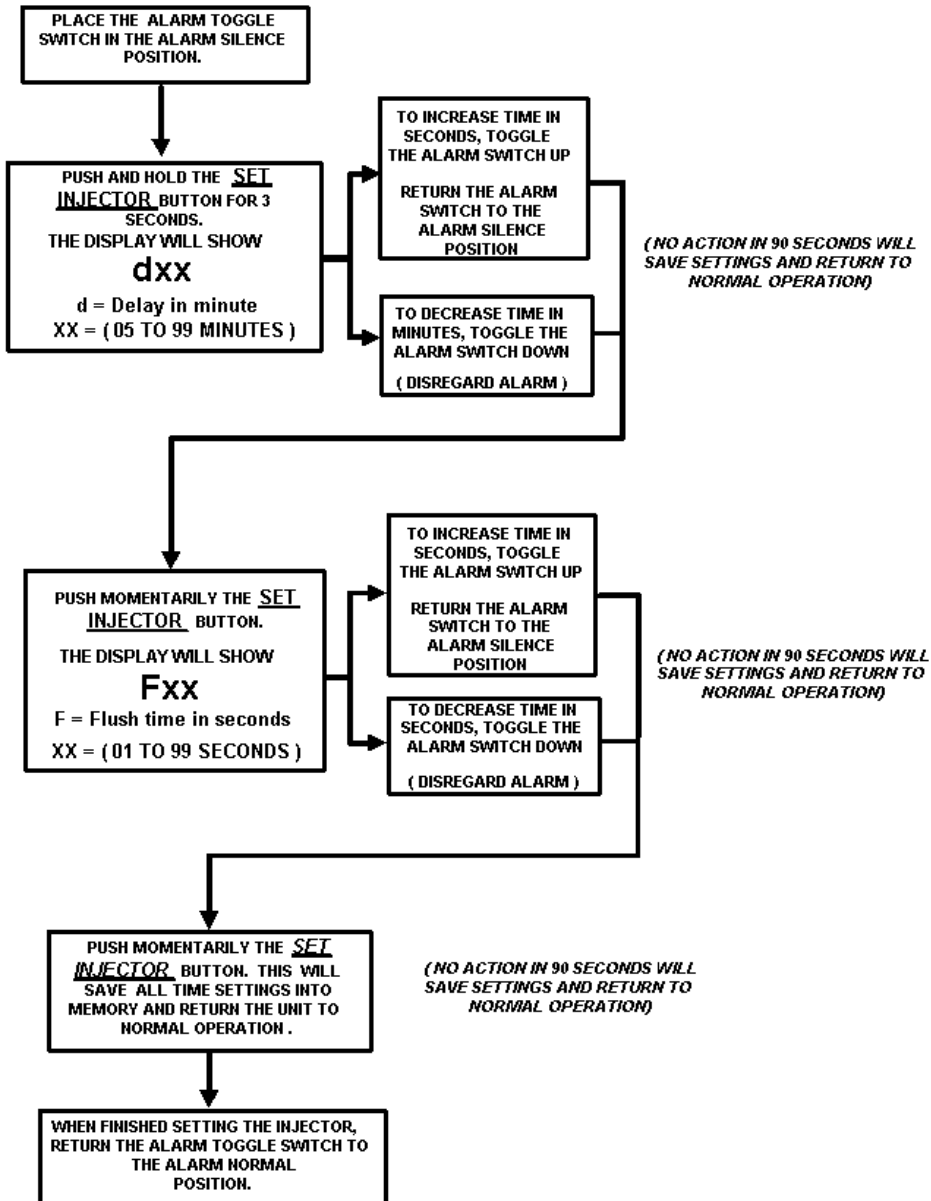

Illustration 7: Flow Chart for Setting iNjector Delay and Flush Time

Specifications for the Mark 3XE Silver Recovery Unit

Pump Station Size.....	6" W x 12L" x 12H"
Rollaround Containment.....	16W" x 16L" x 10H"
Column Weight (Dry).....	18 lb.
Column Weight (Wet).....	35 lb.
Power Requirements.....	115 VAC, 150 Watts
Collection Tank Capacity.....	3.5 Gallons/14 Liters
Processing Speed.....	1 gal/hr.
Pump Flow Rate.....	66 mL/min.
Column Potential (Primary).....	400 Gallons
Column Potential (Tailing).....	800 Gallons
Column Efficiency.....	1.0 ppm or less
Silver Return in Primary Application.....	Up to 50 Troy Ounces